

W. Tombling Ltd

FC Series Wall Mounted Electric Fan Heaters

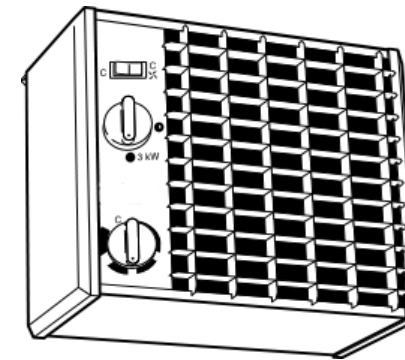

FC3	3000w	230V1N / 400V3N
FC5	5000w	400V3N
FC9	9000w	400V3N

W. Tombling Ltd
Wembley House
Dozens Bank
West Pinchbeck
Spalding
Lincolnshire
PE11 3ND

Tel +44 (0) 1775 640049
Fax +44 (0) 1775 640050

www.tombling.com

PLEASE READ THESE INSTRUCTIONS CAREFULLY BEFORE INSTALLATION AND RETAIN THEM FOR FUTURE REFERENCE.

General Instructions

Please read these instructions carefully before installation and use and keep them for future reference.

Application area

The FC range of wall mounted electric fan heaters are intended for general space heating inside buildings.

The FC range have been tested and comply with the EC EMC 89/336/EEC and LVD 73/23/EEC directives.

The FC range is CE approved.

Protection class: IP44.

Operating conditions

The maximum surrounding air temperature must not exceed +30°C.

Mounting

- Note that the minimum safety distances given in Fig. 2 must be adhered to.
- The heater must be installed with the terminal box to the left, as seen from the front.
- Mark out and drill the holes for the screws as set out in Fig. 3.
- Screw in the screws for the keyholes so that approximately 10 mm remains. Hang-up the unit and tighten the screws.

Electrical connection

The FC series is designed for fixed installation.

The heater(s) should only be wired by a competent person and in accordance with the current edition of the IEE Wiring Regulations (BS 7671: Requirements for Electrical Installations) and any other applicable statutory regulations.

The heaters are fitted with a terminal block for connection to the mains electricity supply and an optional external time switch.

There are two knockout cable entries on the back of the heater which should be fitted with appropriate cable glands to maintain the protection class requirements.

The heater should be preceded by an isolating switch preferably fitted with a status lamp. **The switch MUST NOT be installed ABOVE the heater.**

IMPORTANT

The FC5 and FC9 can only be used on a 400V3N electrical supply.

The FC3 is supplied configured for a 400V3N supply, but can be converted to 230V single phase operation by setting the brass links inside the terminal box and linking the N, L3 and L2 input terminals as shown in Fig. 4.

Optional time switch

An optional time switch - ELU56 is available separately. See Fig. 5 for connection details.

Installations protected by an Residual Current Device (RCD)

If the installation is protected by a Residual Current Device (RCD) which trips when the unit is switched on, this can be caused by a build up of moisture in the heating elements caused by storage in a damp environment or long periods of non use. This should not be regarded as a fault, and is easily rectified by

connecting the heater without an RCD until the element dries out. The drying time can vary from a few hours to a few days.

As a preventive measure run the heater occasionally during periods when the heater will not be used for some time.

Overheat Cutout

If the heater overheats the integrated temperature limiter will trip.

To reset the temperature limiter, isolate the heater from the electricity supply and allow it to cool. Remove the terminal box lid, locate the overheat cutout and press the red button (Fig. 1). Refit the lid and check the heater is working correctly. If the cutout operates again have the heater tested for correct operation.

NOTE! All work inside the heater terminal box should be carried out by a competent person with the heater isolated from the electrical supply.

It is possible that the temperature limiter may have tripped during transport, if the unit does not function the first time it is switched on. Rectify as set out above.

Operation



Output selector switch - Off, reduced output (see specification), full output.



Thermostat -sets the required target temperature.



Toggle switch - in position °C the thermostat only controls the elements, the fan runs continuously.

In position ⚡ the fan is controlled by the thermostat and switches on and off with the elements.

Care

FC series fan heaters do not normally need any maintenance.

However, dirt and dust can build up around the elements and fan causing overheating and representing a fire risk.

Accordingly, the unit should be inspected regularly and cleaned if required.

Important Safety Notices

- **Do not touch the heater while it is operating, the surfaces are hot!**
- **The heater must not be covered, as this will result in the risk of fire!**
- **The heater must not be installed below fixed wall sockets.**
- **Do not point the heater directly at flammable materials.**
- **Ensure the minimum safety distances are adhered to.**

Fig. 3

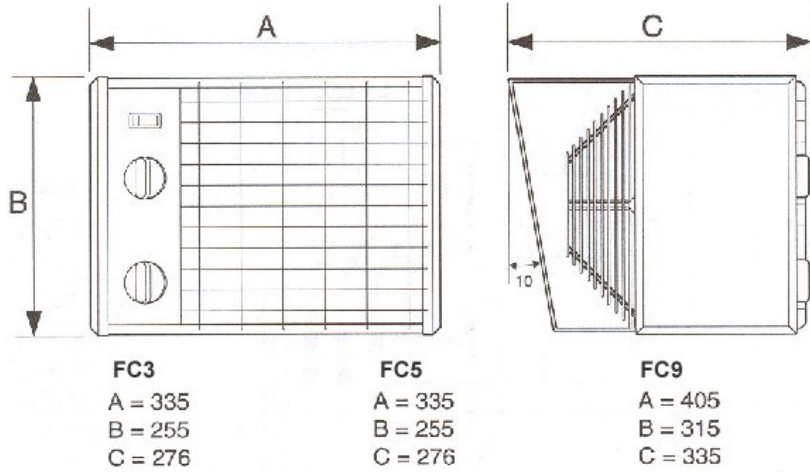

FC3 & FC5

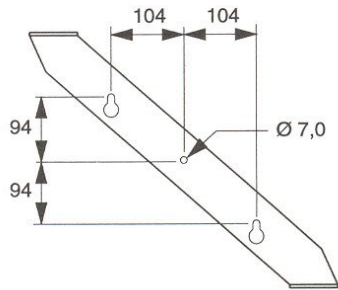

FC9

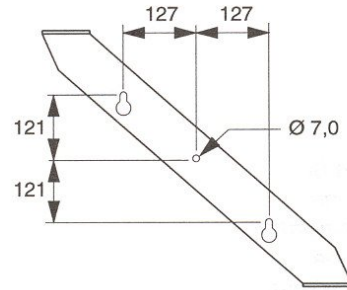
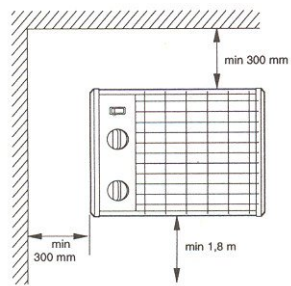

Fig. 2



Minimum safety clearances

Fig. 1

The over heat cut out is inside the lid of the heater. Press firmly to reset.

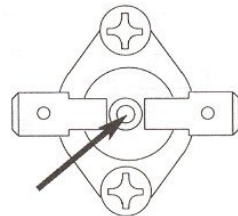
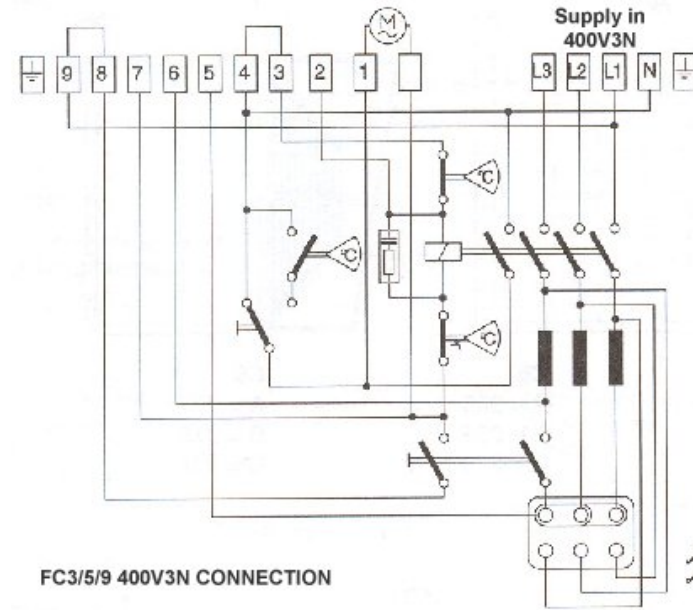

Fig. 4



**FC3 ONLY
230V
CONNECTION**

The FC3 is supplied configured for 400V 3 phase use.

To convert it to 230V single phase, set the brass links as below.

AND link the supply terminals N, L2 and L3 as shown below.

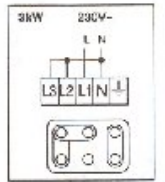
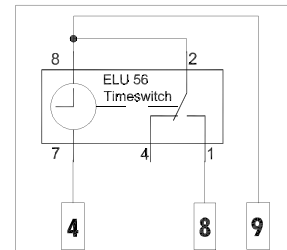

Fig. 5



To fit the optional ELU56 time switch remove the link between heater terminals 8 and 9, and fit the time switch as shown.

Minimum cable size 1.5mm

Specification

Model	FC3	FC5	FC9
Output (kW)	3	5	9
Voltage (V)	230V~ / 400V3N~	400V3N~	400V3N~
Current (A)	13,2 / 4,4	7,3	13,1
Output selector positions (kW)	0-2-3 / 0-1,5-3	0-2,5-5	0-4,5-9
Temperature rise (°C)	27	31	37
Air flow (m³/h)	330	480	720