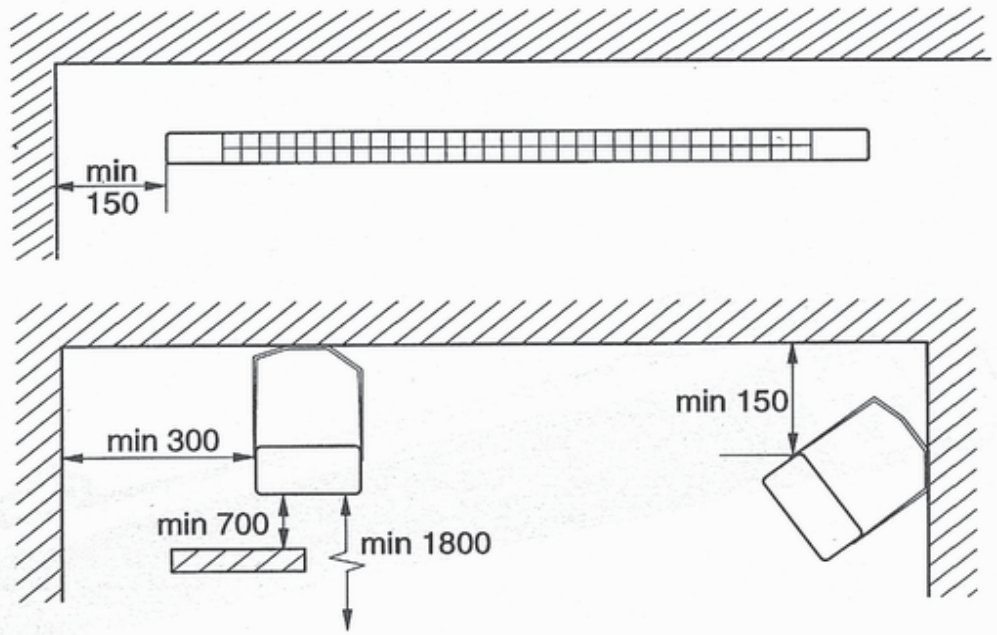
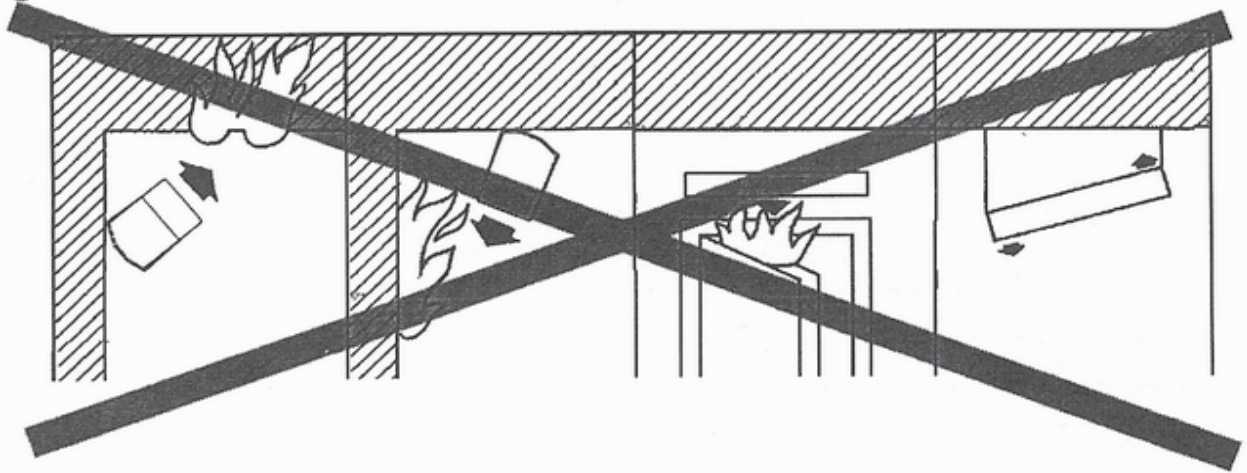


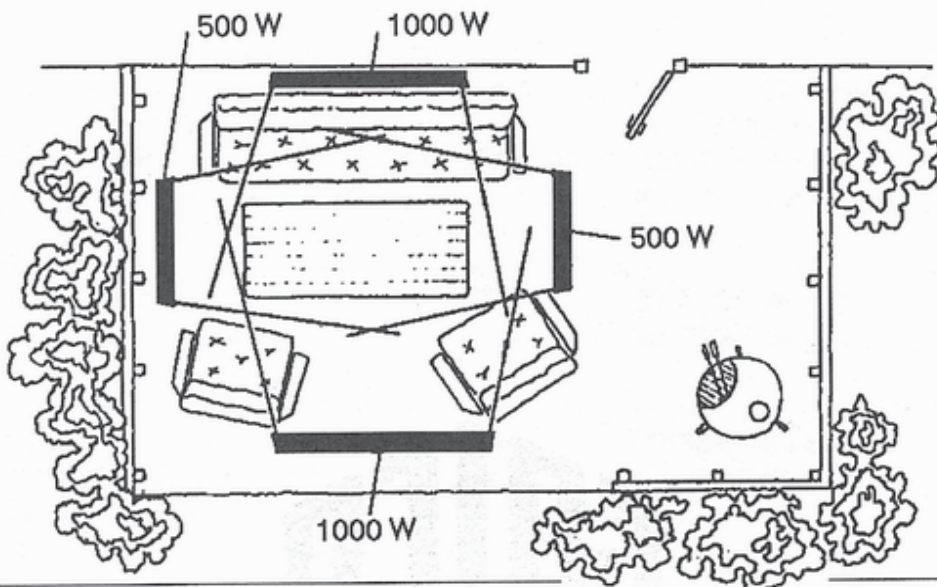
**Fig. 1**

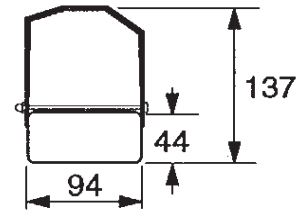
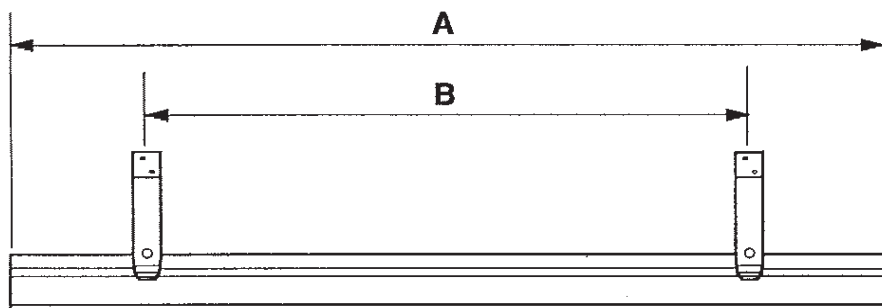


**Fig. 2**

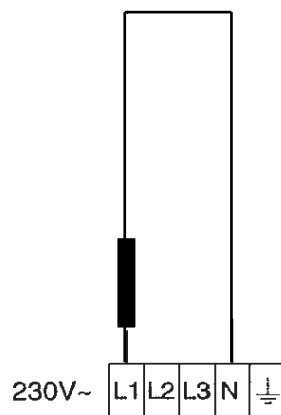


**Fig. 3**





Typ Typpi Type	Effekt Teho Powre	230 V	A	B *)	B (min)
CIR 105	500 W	X	710	500	(300)
CIR 110	1000 W	X	1250	900	(600)
CIR 115	1500 W	X	1755	1200	(800)
CIR 120	2000 W	X	2180	1500	(1000)



---

## Area of use

The radiant heaters are primarily used to create comfortable heating on terraces, balconies, openair restaurants etc. They can also be used for selective heating in storage rooms and workshops.

The FCIR is also approved for installation in bathrooms and shower rooms.

The heater is approved by SEMKO in splash proof design, IP24. It carries the CE-mark and is in compliance with the EMC-directive.

### Positioning

The heaters must be mounted so that they enclose the area which is to be heated, see fig. 3. Suitable distance from the floor is 2—2,5 m. Closer to the floor is not recommended as the additional heat may seem unpleasant.

### Mounting

- First study fig. 1 and 2. NB! The minimum distances in fig. 1 must be kept!
- The heaters may only be mounted horizontally!
- The heater must not be mounted so the circuit breaker can be reached from a bathtub or shower.
- The heater must not be placed directly under a wall-outlet!
- The mounting brackets enable mounting in three different angles for ceiling or wall mounting. Parallel to the wall/ceiling, 18° or 36° angle.
- Choose the desired angle and fasten the bracket onto wall or ceiling. The holes are Ø 5 mm, c-c distance is 25 mm.
- Fasten the heaters, snap into the brackets, and secure it by tightening the securing screws (104 mm long) and the domed nuts (spanner width 7 mm).

### Electrical installation

The electrical installation should be permanent and carried out by a qualified electrician in conformity with prevailing regulations. The FCIR heater must be preceded by an all-pole switch. A terminal block, which enables connection to other heaters is situated on the same end of the heater as the name plate.

Please note that the inlet must be tight. A cable of EKK or EKLK type or similar must be used.

### *Minimum cross section area*

protected by 10A (up to 2 kW) - min. 1,5mm<sup>2</sup>  
protected by 16A (2—3,5 kW) - min. 2,5 mm<sup>2</sup>

### Maintenance

The heater is on the whole made of rustproof material and usually does not require any maintenance. Pollution can in the long run dull the reflectors somewhat. This however has very little affect on its function.

If the heater is very dirty it can be cleaned with compressed air. If the reflector remains dirty it must be replaced by an authorized repairman. The reflector must not be polished as this may damage the protective surface.